

# Dorset Design & Heritage Forum

Wide Open Space: art in the public realm, localism and rural regeneration

A Dorset Design and Heritage Forum conference

26th May 2011, 09-45 to 17-00 @ The Exchange, Sturminster Newton, Dorset

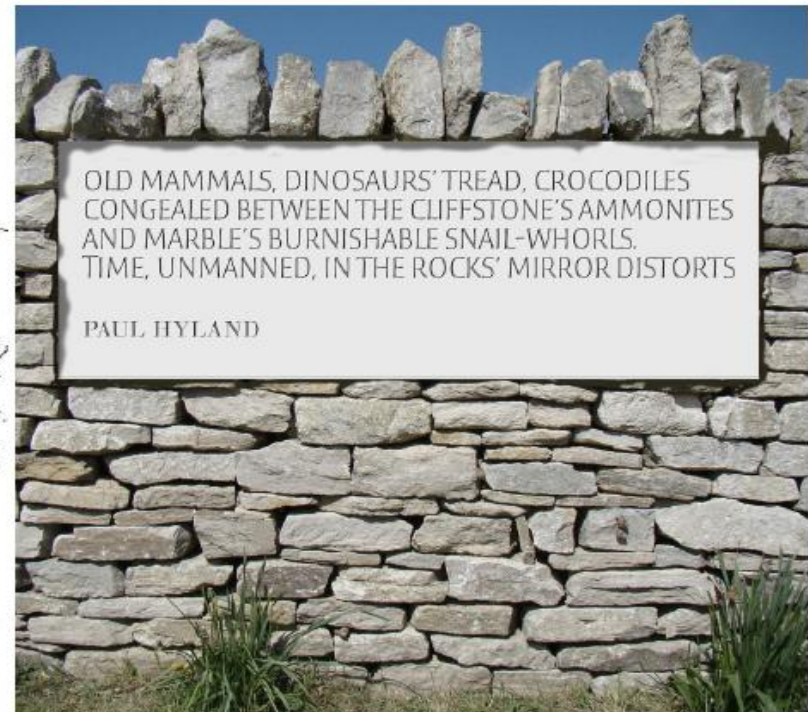

OLD MAMMALS, DINOSAURS' TREAD, CROCODILES  
CONGEALED BETWEEN THE CLIFFSTONE'S AMMONITES  
AND MARBLE'S BURNISHABLE SNAIL-WHORLS.  
TIME, UNMANNED, IN THE ROCKS' MIRROR DISTORTS

PAUL HYLAND

# Dorset Design & Heritage Forum

Launch May 2007



## Places for People

What future do we want for our towns and villages?  
Can we design for stronger and more inclusive communities?  
Can we create distinctive and sustainable places?

Join us at the Herrison Hall on Friday 11th May 2007 to discover Dorset's heritage riches, challenge thinking about good design, explore how to get the best from the planning system and promote creative design for a greener future.

The event will introduce the Dorset Design & Heritage Forum and its activities over the next year.

**To book your place**

Visit [www.dorsetaonb.org.uk](http://www.dorsetaonb.org.uk) or contact Katharine Wright at the Dorset AONB Office on 01305 756782, [k.wright@dorsetcc.gov.uk](mailto:k.wright@dorsetcc.gov.uk)

**Delegate contribution: £15**

Dorset Arts Advisory Group, a partnership of Dorset local authorities and Arts Council England South West

Photo credits: ©Ian Dalgliesh / Natural England; The Architectural Association; Mark Simons / Dorset CC; J.Romer / Cullinan Partnership; and Peter Margerum.



# Dorset Design & Heritage Forum

- To promote quality design that respects Dorset's landscape heritage within community planning, land use planning and arts practice in Dorset.
- To support the county's local authorities, professional practitioners and artists to make Dorset a leading place for design in the rural environment, building on the county's existing strengths.

The term 'design and heritage' is used to describe an approach to the built and natural environment that includes consideration of:

Local distinctiveness

Contemporary culture  
and creativity

Cultural and physical heritage

Environmental sustainability

Construction technology

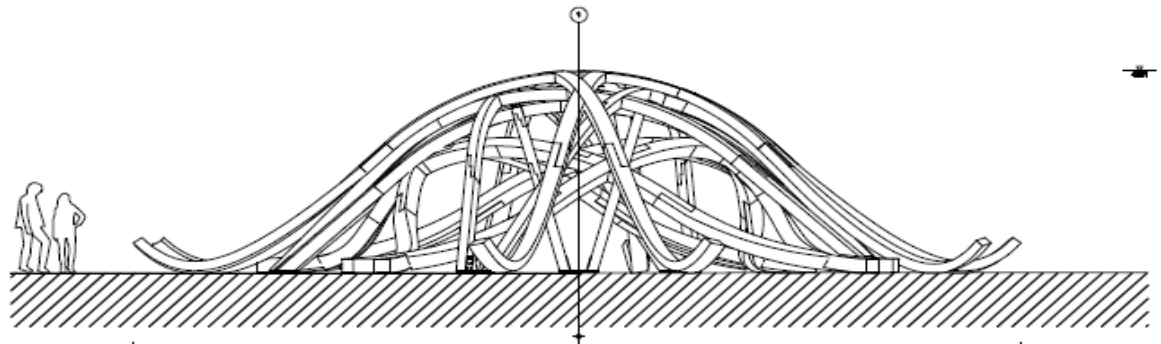

# Wide Open Space: art in the public realm, localism and rural regeneration

## The new Localism agenda Threat or opportunity?

Local decision making to replace regional strategies and structure plans

Scrapping Comprehensive Area Assessments and Local Area Agreements

Neighbourhood plans to be introduced giving local people new rights to shape the development of the communities in which they live (a community right to build) and to permit development in full or in outline, without the need for planning applications/permissions, subject to meeting certain requirements and securing 50% support through a referendum.

The aim is to enable neighbourhoods to “*innovate*”, be “*creative*”, access new resources and “*control their own futures*”. Local authorities will use the Community Infrastructure Levy to meet local aims and ambitions.

# Wide Open Space: art in the public realm, localism and rural regeneration

How do we effectively secure high standards of design quality and environmental conservation at the grassroots level?

How do we equip parishes, community partnerships, civic societies and other community organisations with the necessary tools to secure the locally distinctive, sustainable places they deserve?

How will government and local authorities develop and strengthen their role as advisors and facilitators whilst still undertaking their regulatory roles?

How do we secure the opportunity to support the development of projects that actually make a difference, innovate and empower communities and encourage a deeper ownership of neighbourhoods and environmental resources to the benefit of all?

# Wide Open Space: art in the public realm, localism and rural regeneration



# Wide Open Space: art in the public realm, localism and rural regeneration

The Bill has the potential to effect a significant change in national life, passing power to a local level, creating space for local authorities to lead and innovate, and giving people the opportunity to take control of decisions that matter to them.



# Wide Open Space: art in the public realm, localism and rural regeneration

- What does Localism mean for the quality of our environment and enhancement of our public spaces ?
- How do we continue to be creative in making places in the light of a major re-orientation of public policy and finances ?
- Is there still a role for art and design which addresses key social issues such as housing, transport and other community needs or should the focus return to economics, branding and “iconic” art ?



# Wide Open Space: art in the public realm, localism and rural regeneration

The next stage:

- Use the this conference to discuss the longer term structure and role of the Dorset Design and Heritage Forum and identify new partners and a new way forward
- Consolidate and circulate information available on the achievements of Wide Open Space, Creative Coast and other public realm work which has taken place under the auspices of DDHF
- Build partnerships and secure input from local authorities in Dorset and understand how they intend to deliver the Localism agenda
- Approach key community partnerships/organisations across Dorset and identify opportunities for joint working to secure shared objectives